

LED Well Glass light is design to replace traditional well glass of 70W HPSV, 125W HPMV & 160W MLL Lamp with only 35% of the load for similar illumination. Its specially designed patented conical shape cast aluminium heat sink ensures excellent thermal management and illuminate the area @ 270° uniformly like traditional lamp. It is a perfect LED solution for industry of harsh condition like power plant, foundries, and non hazardous area in chemical and petrochemical industry. Compared to conventional HID Well Glass, it improves reliability, comfort, while reducing energy and maintenance cost dramatically.



FEATURES & BENEFITS

- Luminary efficacy reaches 130 lumens/Watt, ensures more than 65% of energy saving when compared with HID lamp.
- Specially designed heat sink for faster and effective heat dissipation.
- Patented conical shape Led Light creating outstanding illuminance in industrial lighting applications.
- LM-80 compliant high efficiency EMC Package & Photo biologically safe LEDs
- High performance electronic driver with 440V protection for 8 Hrs. (Phase to Phase).
- High Voltage Cut off @ 310 ± 15V with Auto Restart feature.
- Along with the additional 10kV/5kA built-in surge protection device.
- High quality of light by increase CRI up to 80 for all colour temperature.
- Vibration, dust and heat resistant.
- No harmful UV & IR radiation
- Lifetime of over 40000 hours.
- IP65 level of protection against dust penetration & low pressure water jets from any direction.

PRODUCT SPECIFICATIONS

Housing & Finished:

Epoxy powder coated finished Cast aluminium housing (heat sink) for effective thermal management, sturdiness & excellent corrosion resistance.

Glass Cover:

Polycarbonate molded glass cover sealed with frame and fixed to the housing with SS screws. Silicon gasket and Cable gland is used for maintaining ingress protection.

Light source:

High efficiency long life LED module with EMC package SMD type LED mounted on MCPCB. Lumen efficacy of LED ≥150 lm/W with beam angle 120° for uniform distribution.

Electronic Driver:

Built in potted constant current multistage isolated LED driver with < 10% THD, PF ≥0.98, Output Open /Short Circuit protection, Over Voltage protection, 6.5kV Surge Voltage protection & other safety tests as per IS 15885 Part-2/Sec 13 and BIS comply.

Mounting & Maintenance:

Suspended by means of heavy duty electroplated, forged eye-bolt provided with the Fixture.

APPLICATIONS:

- Harsh Industry Application
- Power plant
- Cement Factories
- Foundries
- Warehouse

Note: Well Glass Luminaires are provided with additional 10kV Built in surge protection device.

TECHNICAL DATA

Product Code	Ordering Code	LED Wattage	System Wattage (W)	Rated Voltage (V)	Mains Current (A)	Lumens
PLWW 530 / 35	PLWW 530 / 48 / 100	30	35	230	0.16	4300
PLWW 530 / 40	PLWW 530 / 48 / 110	35	40	230	0.18	4550
PLWW 530 / 50	PLWW 530 / 80 / 90	44	50	230	0.23	6800
PLWW 530 / 60	PLWW 530 / 80 / 110	52	60	230	0.27	7600

Note: Warranty Voids for LED fixtures including Drivers, if individual points of installations are not provided with proper Earthing

TECHNICAL DRAWING

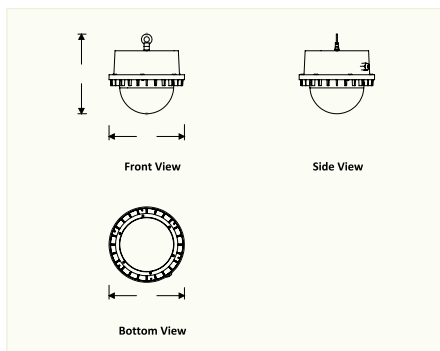

DIMENSION

Product Code	Dimension in mm		Approx Weight
	W	H	
PLWW 530 / 35	175 Ø	210	1.450
PLWW 530 / 40	175 Ø	210	1.450
PLWW 530 / 50	175 Ø	210	1.650
PLWW 530 / 60	175 Ø	210	1.650