

The aesthetics design Area Nova is an affordable LED lighting solution for general area lighting. Its cast aluminium heat sink having an excellent thermal management and resistance to the elements, makes the Area Nova ensures long lifetime, reliability and offers significant energy savings when compared with conventional lamp systems.



FEATURES & BENEFITS

- Robust designed compact housing to suit the General Area Lighting.
- Energy saving upto 55% when compared to conventional floodlights.
- Luminary efficacy reaches 125 lumens/Watt,
- Best Thermal Management by Maintain the "Zero Air Gap" between MCPCB and aluminium modules.
- LM-80 compliant high efficiency EMC package & Photo biologically safe LEDs
- High performance electronic driver with 440V protection for 8 Hrs. (Phase to Phase).
- High quality cool, neutral and warm white light with high colour consistency.
- Vibration, dust and heat resistant.
- No harmful UV & IR radiation
- IP66 level of protection against dust penetration & high pressure water jets from any direction.
- Median useful life $L_{70B_{50}}$ 50000 hours

PRODUCT SPECIFICATIONS

Housing & Glass Frame :

Epoxy powder coated finished Cast aluminium alloy housing (heat sink) for effective thermal management, sturdiness & excellent corrosion resistance. Tempered protective toughened glass sealed with frame and fixed to the housing with SS screws. silicon gasket and Cable gland is used for maintaining ingress protection.

Optics :

Optional High efficiency polycarbonate modular Lens plate of (30°/60°) for narrow & wide beam angle to ensure better uniformity of symmetrical light distribution.

Light source :

High efficiency long life LED module with EMC package SMD type LED mounted on MCPCB. Lumen efficacy of LED ≥ 165 lm/W and viewing angle of 120° to ensure better uniformity.

Electronic Driver :

Powered by inbuilt, constant current multistage isolated LED driver with < 10% THD, PF ≥ 0.98 , Output Open /Short Circuit Protection, Over Voltage protection, 6.5kV Surge Voltage protection & other safety tests as per IS 15885 Part-2/Sec 13 and BIS comply.

Mounting & Maintenance :

Wall or surface mounting using adjustable MS cradle of thickness 3.0 mm provided with the fixture by 3 circular slots of 10mm \varnothing at center distance of 60 mm.

APPLICATIONS :

- Parking lots
- Hording & Facades Lighting
- Factories & Warehouse
- Industries perimeter lighting
- General Area Lighting

TECHNICAL DATA

Product Code	Ordering Code	LED Wattage	System Wattage (W)	Rated Voltage (V)	Mains Current (A)	Lumens
PLFL 514 / 75	PLFL 514 / 30 / 700	65	75	230	0.33	9400

Note: Warranty Voids for LED fixtures including Drivers, if individual points of installations are not provided with proper Earthing

TECHNICAL DRAWING

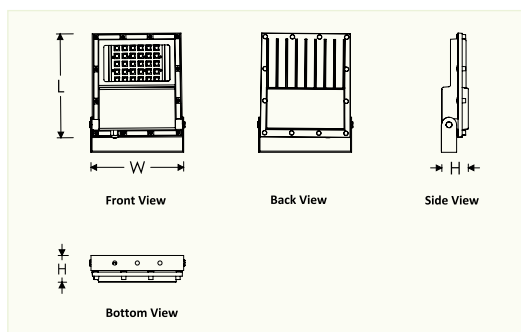

DIMENSION

Product Code	Dimension in mm			Approx Weight
	L	W	H	
PLFL 514 / 75	275	245	70	3.950