

Road star was created to help those responsible for lighting our world succeeds in their energy conservation goals. It is designed to achieve better light uniformity and maximum spacing between poles, while ensuring sufficient light on the road. Its die-cast aluminium housing was designed to achieve an over 50,000 hour lifespan, to minimize maintenance requirements and maximize performance and offers significant energy savings when compared with conventional lamp systems. Road star offers an affordable LED road lighting solution for both minor and major road applications.



**FEATURES & BENEFITS**

- Luminary efficacy reaches 125 lumens/Watt, gives more than 60% of energy saving with full compliance to road lighting safety standards.
- Best Thermal Management by Maintain the "Zero Air Gap" between MCPCB and aluminium modules for fastest heat dissipation.
- LM-80 compliant high efficiency ceramic package & Photo biologically safe LEDs
- High performance electronic driver with 440V protection for 8 Hrs. (Phase to Phase).
- Along with the additional 10kV/5kA built-in surge protection device.
- Multiple lumen packages and optics to suit most roadway applications.
- Superior W/m2 performance delivered through different optics for greater flexibility to fit different road applications.
- Driver Compartment designed to suit top maintenance.
- High quality cool, neutral and warm white light with high colour consistency.
- Vibration, dust and heat resistant.
- No harmful UV & IR radiation
- Ip66 level of protection against dust penetration & high pressure water jets from any direction.
- Median useful life  $L_{70}B_{50}$  50000 hours

**PRODUCT SPECIFICATIONS**

**Housing & Glass Frame :**

Epoxy powder coated finished Cast aluminium alloy housing (heat sink) for effective thermal management, sturdiness & excellent corrosion resistance. Tempered protective toughened glass sealed with frame and fixed to the housing with SS screws. Silicon gasket and Cable gland is used for maintaining ingress protection.

**Optics:**

Optional High efficiency polycarbonate modular Lens plate of (120° x 60°) to ensure asymmetrical batwing light distribution.

**Light source :**

High efficiency long life LED module with Ceramic package SMD type LED mounted on MCPCB. Lumen efficacy of LED  $\geq 165$  lm/W and viewing angle of 120° to ensure better uniformity.

**Electronic Drive :**

Powered by inbuilt, constant current multistage isolated LED driver with < 10% THD, PF  $\geq 0.98$ , Output Open /Short Circuit Protection, Over Voltage protection, 6.5kV Surge Voltage protection & other safety tests as per IS 15885 Part-2/Sec 13 and BIS comply.

**Mounting & Maintenance :**

Suitable for pole mounting with bracket Arm OD of 60mm (max.) 100w & above. Recommended mounting height with suitable in ground reinforcement is 7-10 m.

**APPLICATIONS :**

- Highways and major road
- City road lighting
- Industries perimeter lighting

**Note:** Road star Luminaires are provided with additional 10kV Built in surge protection device (SPD).

**TECHNICAL DATA**

Product Code	Ordering Code	LED Wattage	System Wattage (W)	Rated Voltage (V)	Mains Current (A)	Lumens
PLSL 504 / 75	PLSL 504 / 30 / 700	65	75	230	0.34	9400
PLSL 504 / 100	PLSL 504 / 40 / 700	87	100	230	0.46	12550
PLSL 504 / 150	PLSL 504 / 60 / 700	131	150	230	0.69	18800

**Note:** Warranty Voids for LED fixtures including Drivers, if individual points of installations are not provided with proper Earthing

**TECHNICAL DRAWING**

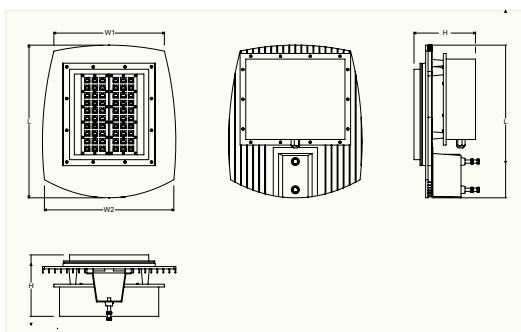

**DIMENSION**

Product Code	Dimension in mm			Approx Weight
	L	W	H	
PLSL 504 / 75	322	228	145	3.700
PLSL 504 / 100	366	280	145	5.100
PLSL 504 / 150	375	325	145	6.200