

The energy-saving FLP Floodlight is an ideal solution for a wide range of area lighting applications. Its specially designed circular cast aluminum heat sink combines aesthetics with excellent thermal management and resistance to harsh environmental conditions, ensuring superior reliability. Featuring a separate driver compartment for easy top maintenance, this luminaire delivers outstanding performance and an extended lifespan, taking area lighting to a whole new level.



FEATURES & BENEFITS

- Best Thermal Management by Maintain the "Zero Air Gap" between MCPCB and aluminium modules ensuring sturdy performance.
- Reduces energy consumption by up to 55% compared to conventional floodlights.
- Luminaire efficacy reaches 125 lumens/Watt,
- LM-80 compliant high efficiency & Photo biologically safe LEDs
- High performance electronic driver with 440V protection for 8 Hrs. (Phase to Phase).
- High Voltage Cut off @ 310 ± 15V with Auto Restart feature.
- Along with the additional 10kV/5kA built-in surge protection device.
- Driver Compartment designed to suit top maintenance.
- High quality of light by increase CRI up to 80 for all colour temperature.
- Vibration, dust and heat resistant.
- No harmful UV & IR radiation
- Median useful life L70B50 50000 hours.
- IP66 level of protection against dust penetration & high pressure water jets from any direction.

PRODUCT SPECIFICATIONS

Housing & Glass Frame :

Epoxy powder coated finished Castaluminium housing (heat sink) for effective thermal management, sturdiness & excellent corrosion resistance. Tempered protective toughened glass sealed with glass ring and fixed to the housing with SS Allen bolts. Neoprene gasket is used for maintaining ingress protection.

Driver Compartment :

Epoxy powder coated finished Cast aluminium housing for sturdiness & excellent corrosion resistance. Neoprene gasket is used for maintaining ingress protection.

Note: Flood light luminaires are provided with additional 10kV Built in surge protection device (SPD).

Light source :

High efficiency long life LED module with EMC package SMD type LED mounted on MCPCB. Lumen efficacy of LED ≥150lm/W with beam angle 120° for uniform distribution.

Electronic Driver :

Built in potted constant current multistage isolated LED driver with < 10% THD, PF ≥0.98, Output Open /Short Circuit protection, Over Voltage protection, Surge Voltage protection & other safety tests as per IS 15885 Part-2/Sec 13 and BIS comply.

Mounting & Maintenance :

Surface mounting using fixed MS bracket of thickness 4.0 mm provided with the fixture by 3 circular slots of 10mm Ø at center distance of 60mm.

Note: CI Base Plate are available on request.

APPLICATIONS :

- Oil Rings & Refineries
- Mines
- Chemical Factories
- Petrochemical Industries

TECHNICAL DATA

Product Code	Ordering Code	LED Wattage	System Wattage (W)	Rated Voltage (V)	Mains Current (A)	Lumens
PLFF 540 / 100	PLFF 540 / 96 / 150	87	100	230	0.46	12700
PLFF 540 / 150	PLFF 540 / 144 / 150	131	150	230	0.69	19100

Note: Warranty Voids for LED fixtures including Drivers, if individual points of installations are not provided with proper Earthing

TECHNICAL DRAWING

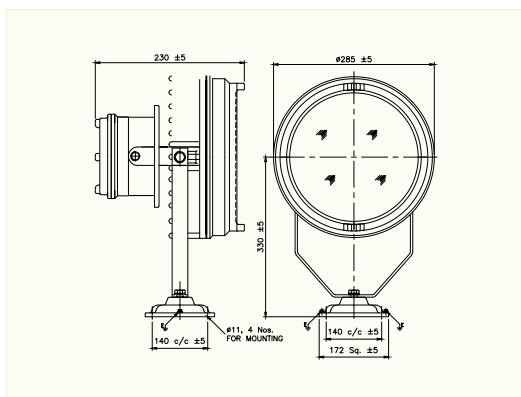

DIMENSION

Product Code	Dimension in mm		Approx Weight
	W	H	
PLFF 540 / 100	240 Ø	170	5.900
PLFF 540 / 150	240 Ø	205	7.250