

Square back family has extremely low power consumption of this LED solution results in significant energy saving compared with traditional CFL down lights. There is also range of different sizes and outputs, and an array of different accessories, ensuring maximum flexibility in customizing the right light effect for your application. Best of all, this family of luminaires delivers specification grade performance and better glare control. These down lights are ideal for applications in offices, shops, hotels and hospitals where an energy efficient general lighting solution is needed.



FEATURES & BENEFITS

- High system efficacy, resulting in up to 60% energy savings compared with conventional CFL down lights.
- Uniform and diffused lighting effect.
- Optimized heat sink design, enabling 50k hrs long lifetime.
- High performance electronic driver ensures zero maintenance
- Better color consistency.
- Multiple lumen packages and optics to suit most interior applications
- Environment-friendly as it does not contain Mercury.
- No harmful UV & IR radiation.
- Instant light with low running temperatures.
- Quick installation, easy to install.
- Multiple lumen packages and optics to suit most interior applications.

PRODUCT SPECIFICATIONS

Housing & Glass Frame :

Epoxy powder coated finished Extruded aluminium housing and Aluminium sheet used as a back cover (heat sink) for effective thermal management, sturdiness & excellent corrosion resistance

Optics :

High transmittance polystyrene opal diffuser for glare free symmetric light distribution.

Light source :

High efficiency long life LED module with plastic package SMD type LED mounted on MCPCB. Lumen efficacy of LED ≥ 135 lm/W and viewing angle of 120° to ensure better uniformity.

Electronic Driver :

Powered by an independent, constant current isolated LED driver with <20% THD, PF ≥ 0.95 , Output Open /Short Circuit Protection, Over Voltage protection, 2.5kV Surge Voltage protection & other safety tests as per IS 15885 Part-2/Sec 13 and BIS comply.

Mounting & Maintenance :

Fixing into false ceiling by means of 2 nos. SS springs clips

APPLICATIONS :

- Shopping malls
- Restaurants
- Hotel lobbies / Waiting areas
- Modern gyms / Spa
- Corporate offices

TECHNICAL DATA

Product Code	Ordering Code	LED Wattage	System Wattage (W)	Rated Voltage (V)	Mains Current (A)	Lumens
PLDL 563 / 6	PLDL 563 / 36 / 50	5.5	6	230	0.03	750
PLDL 563 / 12	PLDL 563 / 64 / 50	10.5	12	230	0.05	1350
PLDL 563 / 18	PLDL 563 / 100 / 50	16.5	18	230	0.08	2100
PLDL 563 / 24	PLDL 563 / 125 / 50	20.5	24	230	0.11	2600

Note: Warranty Voids for LED fixtures including Drivers, if individual points of installations are not provided with proper Earthing

TECHNICAL DRAWING

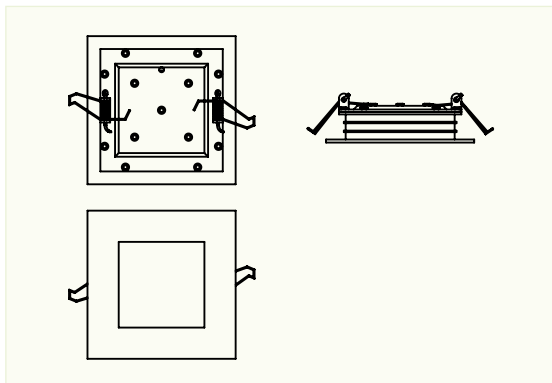

DIMENSION

Product Code	Outer Frame Dimension			Cutoff Dimension	
	L	W	H	L	W
PLDL 563 / 6	125	125	20	100	100
PLDL 563 / 12	150	150	20	125	125
PLDL 563 / 18	175	175	20	150	150
PLDL 563 / 25	200	200	20	175	175